

Enjoy the rich rewards of quality water

AvantaPure® Professional Series
Water Treatment System by GE

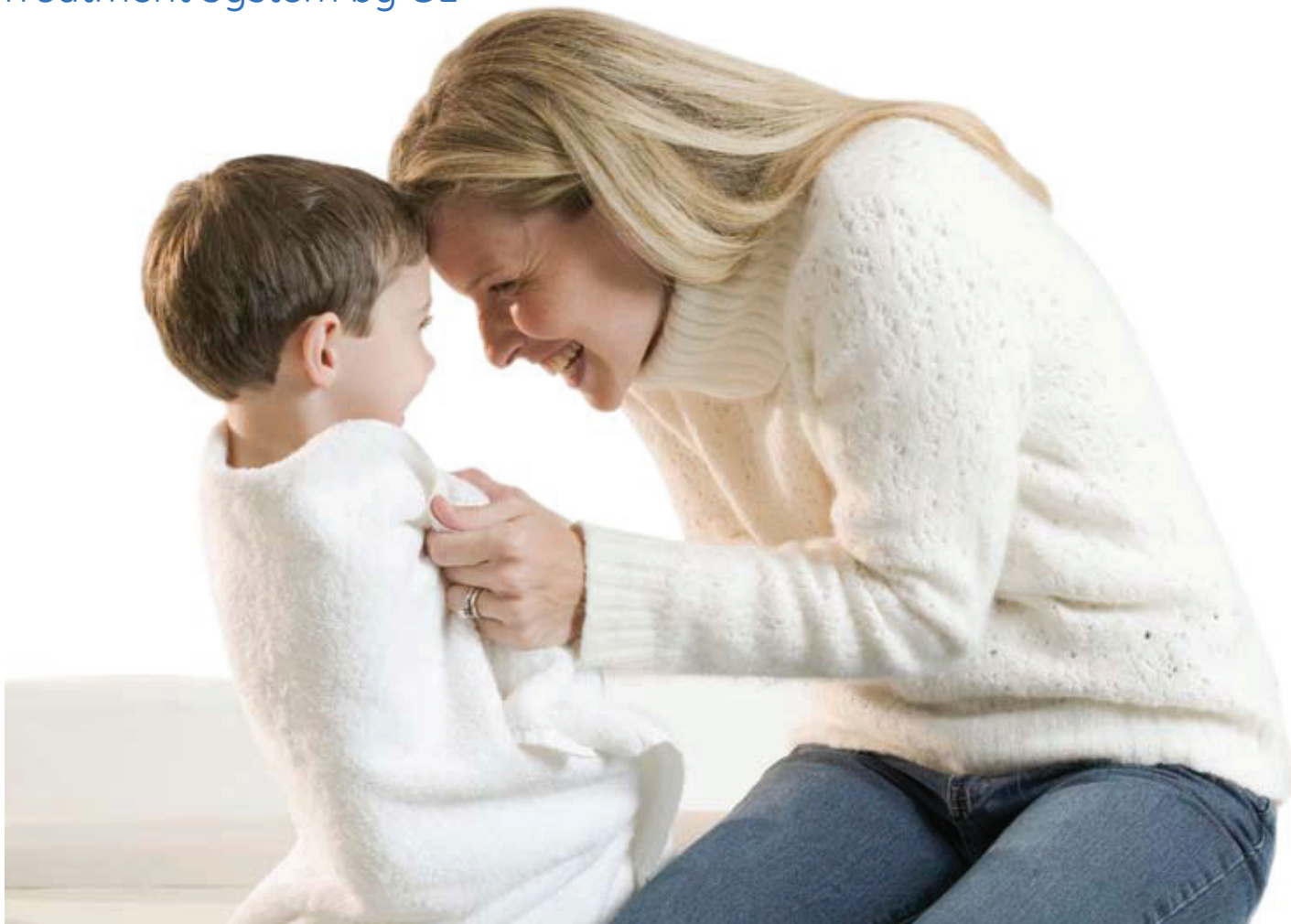

imagination at work

Hard water is hard on your home.

When your home uses hard unconditioned water, undesirable elements (calcium, magnesium, chlorine, iron and sediment) enter from wells or municipal water supplies. They take a toll on your plumbing, appliances, linens, glassware and more. And that takes a toll on your wallet.

The solution is an AvantaPure® Professional Series Water Treatment System by GE. By supplying conditioned water throughout your home, it lets you enjoy the rich rewards of quality water.



The tell-tale signs.

You can taste, see and feel the evidence of unconditioned water in your home:

- Scratchy towels
- Stiff bed linens and clothes
- Fabrics that break down prematurely
- The taste of chlorine and iron in tap water
- Soaps, shampoos and detergents that lather poorly and rinse slowly
- Cloudy, spotted glassware that even the best dishwasher can't fix
- Mineral deposits on bathroom and kitchen plumbing fixtures
- Hard-to-remove stains in sinks and toilets



The hidden costs.

It's the evidence you don't see that costs the most. Unconditioned water degrades your home's plumbing, and robs you in other, less obvious ways:

- Mineral build-up in pipes can reduce water flow and lead to clogged water pipes
- Water-using appliances suffer increased wear-and-tear
- More money is spent on soaps, shampoos and cleaning products
- Extra time is spent cleaning bathroom and kitchen fixtures, tile and sinks



How the AvantaPure® by GE treats your water

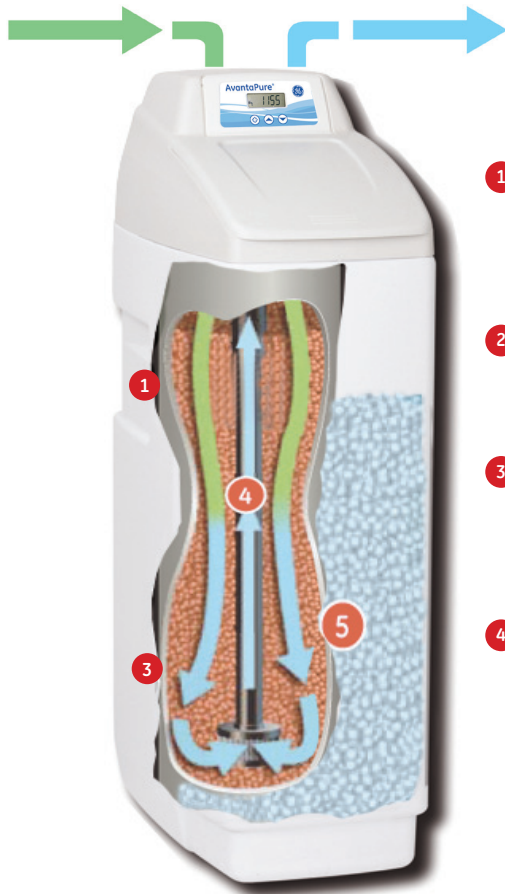

- 1 Untreated water containing impurities passes through a bed of extremely small resin beads.
- 2 Undesirable minerals are drawn to the resin beads and attach to the surface.
- 3 Virtually all unwanted minerals are removed when the water reaches the bottom of the tank.
- 4 The treated water passes up through the riser tube and is distributed throughout the house.

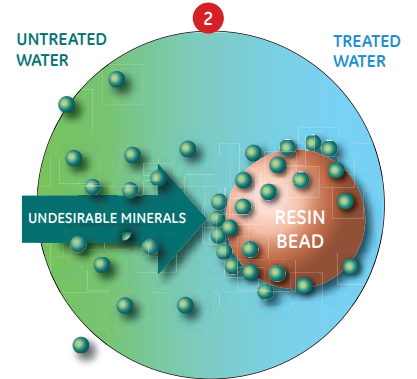

- 5 Regenerant from the storage tank is used to recharge the resin beads.

Chlorine reduction can be achieved with this system – ask your dealer for details.

The AvantaPure advantage

The AvantaPure Water Treatment System by GE saves money and conserves resources through our Upow Proportional Regeneration process. This innovative treatment process only regenerates the depleted portion of the resin bed, which also makes this system eco-friendly.

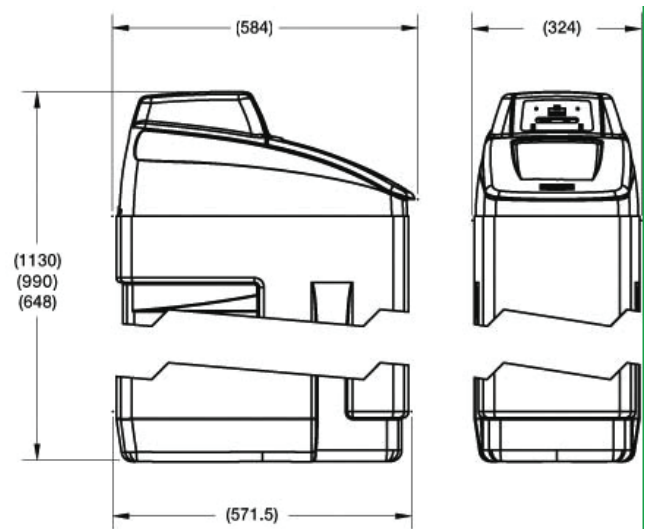

The rewards of conditioned water

Quality conditioned water enhances your home life in ways both subtle and significant. Tap water tastes better. Towels and sheets feel better. Glassware gets a renewed sparkle. Tile shines, and faucets gleam. Soaps and shampoos have a richer lather that rinses more completely. Detergents and cleaning agents perform better. Inside your home's plumbing, water is running clearer and water-using appliances last longer.

It all comes from the AvantaPure® Professional Series Water Treatment System by GE. It's eco-friendly, conserves energy and has the long-term reliability you expect from GE.

The reliable AvantaPure system is designed to deliver the benefits of comfortable, conditioned water for a long time to come.

- Less spending on soaps, detergents and cleaning supplies... up to a 50% savings!
- Showering leaves you with a fresh, clean feel
- Machine washables rinse cleaner, feel softer and retain color longer
- Dishes can be rinsed without costly drying agents

When it comes to making life easier, saving money and feeling better in your own home, the choice shouldn't be hard at all.



Quality water from a trusted name

An AvantaPure® Water Treatment System delivers the benefit of GE innovation and leadership in water processing technology. The result is quality water throughout your home.



AVANTAPURE WATER TREATMENT SYSTEM BY GE

- **NEVER FORGETS**
Memory back-up retains settings during power outages.
- **SMART THINKING**
A full digital electronic controller is in command through all stages of treatment, adjusting in response to changes in water usage.
- **EFFICIENCY EXPERT**
Only regenerates when needed – saves time, energy and money.
- **ONLY THE FINEST**
Components constructed of the very best materials to withstand corrosion and wear.
- **GOOD LOOKS**
Designed for eye appeal, like today's finest appliances.



AVANTAPURE REVERSE OSMOSIS SYSTEM BY GE

- **BETTER BEVERAGES**
Improved flavor and clarity in coffee, juice and tea.
- **A CLEAR DIFFERENCE**
Ice cubes will be clearer and harder.
- **QUALITY ON TAP**
Eliminate the hassle and expense of bottled water – every glass of water tastes great!
- **EAT HEALTHY**
Fruits and vegetables retain more nutrients when cooked in reverse osmosis water.
- **MAINTENANCE MADE EASY**
Only requires simple filter cartridge replacement – nothing to scrub or clean.
- **A GREAT FIT**
Compact design makes it an easy fit under your kitchen sink.
- **STAY DRY**
Innovative manifold design eliminates tubing between filtration stages, which can be a source of leaks.
- **FILTRATION TIMES FOUR**
Four-stage filtration process reduces waterborne impurities*.
- **A STEADY STREAM**
Attractive sink-mount faucet connects to a large-capacity (1.8 gallon) storage tank.



The AvantaPure RO by GE is Tested and Certified by NSF International to NSF/ANSI-Standard 58.

* For specific reduction levels please refer to the performance data sheet available through your dealer.

Only available through authorized dealers of the
AvantaPure® Water Treatment System by GE.

Pentair Water Belgium n.v.
Tel. + 32 14 25 99 11
belgium.water@pentair.com

Pentair Water France SAS
Tel. + 33 1 39 24 15 00
france.water@pentair.com

Pentair Water Italy S.r.l.
Tel. + 39 02 93 27 111
italy.water@pentair.com

Pentair Water Purification EMEA
marketing.prfemea@pentair.com
www.avantapure.com



Dealer
AvantaPure

GE is a trademark of General Electric Company
and is under license by Pentair Water
Residential Filtration, LLC, Glendale, WI



©2009, Pentair Residential Filtration, LLC
Printed in USA, P/N 3001775 Rev. C

www.avantapure.com